

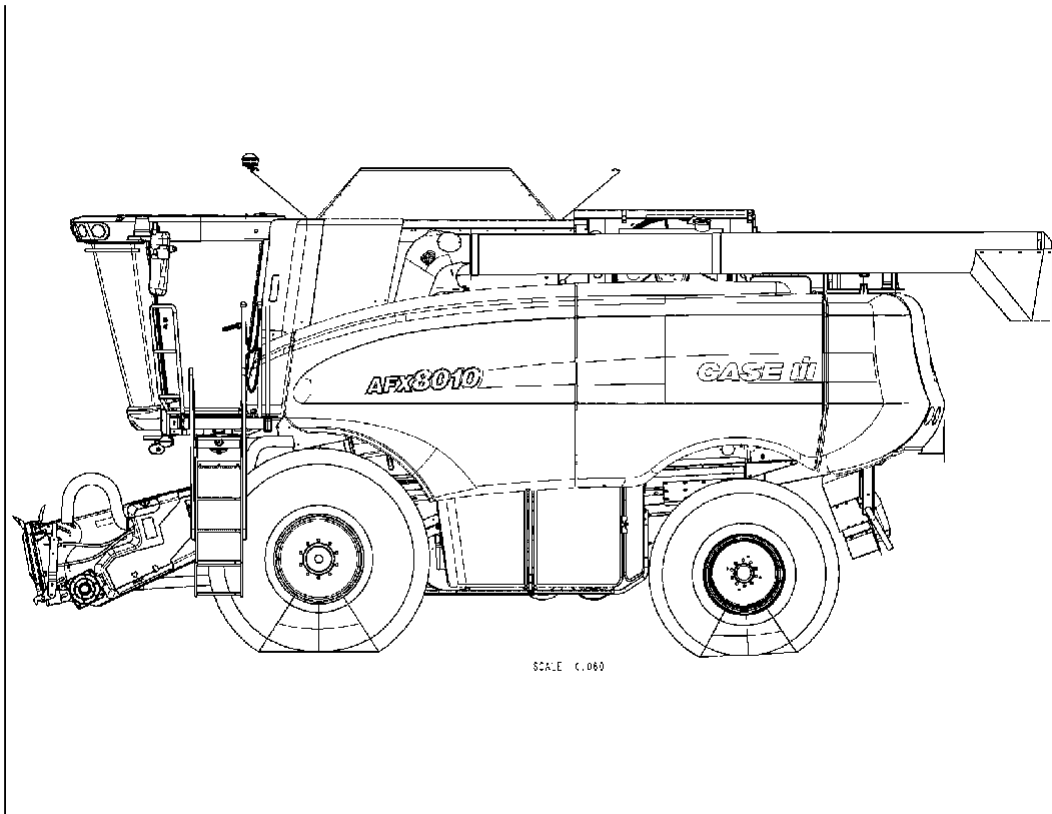

REPAIR MANUAL



AFX8010

Contents

INTRODUCTION	
DISTRIBUTION SYSTEMS	A
POWER PRODUCTION	B
POWER TRAIN	C
TRAVELLING	D
BODY AND STRUCTURE	E
TOOL POSITIONING	G
CROP PROCESSING	K



INTRODUCTION

Contents

INTRODUCTION

Foreword (- A.10.A.40)
AFX8010

3

Foreword (- A.10.A.40)

AFX8010

Technical Information

This manual has been produced by a new technical information system. This new system is designed to deliver technical information electronically through CDROM and in paper manuals. A coding system called ICE has been developed to link the technical information to other Product Support functions e.g. Warranty.

Technical information is written to support the maintenance and service of the functions or systems on a customers machine. When a customer has a concern on his machine it is usually because a function or system on his machine is not working at all, is not working efficiently, or is not responding correctly to his commands. When you refer to the technical information in this manual to resolve that customers concern, you will find all the information classified using the new ICE coding, according to the functions or systems on that machine. Once you have located the technical information for that function or system then you will find all the mechanical, electrical or hydraulic devices, components, assemblies and sub-assemblies for that function or system. You will also find all the types of information that have been written for that function or system, the technical data (specifications), the functional data (how it works), the diagnostic data (fault codes and troubleshooting) and the service data (remove, install adjust, etc.).

By integrating this new ICE coding into technical information , you will be able to search and retrieve just the right piece of technical information you need to resolve that customers concern on his machine. This is made possible by attaching 3 categories to each piece of technical information during the authoring process.

The first category is the Location, the second category is the Information Type and the third category is the Product:

- LOCATION - is the component or function on the machine, that the piece of technical information is going to describe e.g. Fuel tank.
- INFORMATION TYPE - is the piece of technical information that has been written for a particular component or function on the machine e.g. Capacity would be a type of Technical Data that would describe the amount of fuel held by the Fuel tank.
- PRODUCT - is the model that the piece of technical information is written for.

Every piece of technical information will have those 3 categories attached to it. You will be able to use any combination of those categories to find the right piece of technical information you need to resolve that customers concern on his machine.

That information could be:

- the description of how to remove the cylinder head
- a table of specifications for a hydraulic pump
- a fault code
- a troubleshooting table
- a special tool

How to Use this Manual

This manual is divided into Sections. Each Section is then divided into Chapters. Contents pages are included at the beginning of the manual, then inside every Section and inside every Chapter. An alphabetical Index is included at the end of a Chapter. Page number references are included for every piece of technical information listed in the Chapter Contents or Chapter Index.

Each Chapter is divided into four Information types:

- Technical Data (specifications) for all the mechanical, electrical or hydraulic devices, components and assemblies.
- Functional Data (how it works) for all the mechanical, electrical or hydraulic devices, components and assemblies.

- Diagnostic Data (fault codes, electrical and hydraulic troubleshooting) for all the mechanical, electrical or hydraulic devices, components and assemblies.
- Service data (remove disassembly, assemble, install) for all the mechanical, electrical or hydraulic devices, components and assemblies.

Sections

Sections are grouped according to the main functions or a systems on the machine. Each Section is identified by a letter A, B, C etc. The amount of Sections included in the manual will depend on the type and function of the machine that the manual is written for. Each Section has a Contents page listed in alphabetic/numeric order. This table illustrates which Sections could be included in a manual for a particular product.

PRODUCT	SECTION										
	A - Distribution Systems										
	B - Power Production										
	C - Power Train										
	D - Travelling										
	E - Body and Structure										
	F - Frame Positioning										
	G - Tool Positioning										
	H - Working Arm										
	J - Tools and Couplers										
	K - Crop Processing										
L - Field Processing											
Tractors	X	X	X	X	X	X		X	X		
Vehicles with working arms: backhoes, excavators, skid steers,	X	X	X	X	X	X	X	X	X		
Combines, forage harvesters, balers,	X	X	X	X	X	X	X	X	X	X	
Seeding, planting, floating, spraying equipment,	X	X	X	X	X	X	X		X		X
Mounted equipment and tools,					X	X	X		X		

This manual contains these Sections. The contents of each Section are explained over the following pages.

Contents

INTRODUCTION	
DISTRIBUTION SYSTEMS	A
POWER PRODUCTION	B
POWER TRAIN	C
TRAVELLING	D
BODY AND STRUCTURE	E
TOOL POSITIONING	G
CROP PROCESSING	K

Section Contents

SECTION A, DISTRIBUTION SYSTEMS

This Section covers the main systems that interact with most of the functions of the product. It includes the central parts of the hydraulic, electrical, electronic, pneumatic, lighting and grease lubrication systems. The components that are dedicated to a specific function are listed in the Chapter where all the technical information for that function is included.

Contents of DISTRIBUTION SYSTEMS - A

PRIMARY HYDRAULIC POWER SYSTEM	A.10.A
AFX8010	
SECONDARY HYDRAULIC POWER SYSTEM	A.12.A
AFX8010	
ELECTRICAL POWER SYSTEM	A.30.A
AFX8010	
LIGHTING SYSTEM	A.40.A
AFX8010	
ELECTRONIC SYSTEM	A.50.A
AFX8010	

SECTION B, POWER PRODUCTION

This Section covers all the functions related to the production of power to move the machine and to drive various devices.

Contents of POWER PRODUCTION - B

ENGINE	B.10.A
AFX8010	
FUEL AND INJECTION SYSTEM	B.20.A
AFX8010	
AIR INTAKE SYSTEM	B.30.A
AFX8010	
EXHAUST SYSTEM	B.40.A
AFX8010	
ENGINE COOLANT SYSTEM	B.50.A
AFX8010	
LUBRICATION SYSTEM	B.60.A
AFX8010	
STARTING SYSTEM	B.80.A
AFX8010	

SECTION C, POWER TRAIN

This Section covers all the functions related to the transmission of power from the engine to the axles and to internal or external devices and additional Process Drive functions.

Contents of POWER TRAIN - C

POWER COUPLING Fixed Coupling	C.10.B
AFX8010	
TRANSMISSION Mechanical	C.20.B
AFX8010	
TRANSMISSION Hydrostatic	C.20.F
AFX8010	
FRONT PTO Mechanical	C.42.B
AFX8010	
PROCESS DRIVE Primary process drive	C.50.B
AFX8010	
TRANSMISSION LUBRICATION SYSTEM	C.90.A
AFX8010	

SECTION D, TRAVELLING

This Section covers all the functions related to moving the machine, including tracks, wheels, steering and braking. It covers all the axles both driven axles and non-driven axles, including any axle suspension.

Contents of TRAVELLING - D

FRONT AXLE	D.10.A
AFX8010	
REAR AXLE	D.12.A
AFX8010	
2WD-4WD SYSTEM Hydraulic	D.14.C
AFX8010	
STEERING Hydraulic	D.20.C
AFX8010	
SERVICE BRAKE Hydraulic	D.30.C
AFX8010	
PARKING BRAKE Hydraulic	D.32.C
AFX8010	
WHEELS AND TRACKS Wheels	D.50.C
AFX8010	

SECTION E, BODY AND STRUCTURE

This Section covers all the main functions and systems related to the structure and body of the machine. Including the frame, the shields, the operator's cab and the platform.

Contents of BODY AND STRUCTURE - E

FRAME Primary frame	E.10.B
AFX8010	
SHIELD	E.20.A
AFX8010	
OPERATOR AND SERVICE PLATFORM	E.30.A
AFX8010	
USER CONTROLS AND SEAT	E.32.A
AFX8010	
USER CONTROLS AND SEAT Operator seat	E.32.C
AFX8010	
USER CONTROLS AND SEAT Instructor seat	E.32.D
AFX8010	
USER PLATFORM	E.34.A
AFX8010	
ENVIRONMENT CONTROL Heating, Ventilation and Air Conditioning	E.40.D
AFX8010	
SAFETY SECURITY ACCESSORIES Safety	E.50.B
AFX8010	
DECALS AND PLATES	E.60.A
AFX8010	

SECTION G, TOOL POSITIONING

This Section covers all the functions related to the final and/or automatic positioning of the tool once the tool is positioned using the Working Arm or the machine frame.

Contents of TOOL POSITIONING- G

LIFTING AFX8010	G.10.A
TILTING AFX8010	G.20.A
LEVELING AFX8010	G.30.A

SECTION K, CROP PROCESSING

This Section covers all the functions related to crop processing.

Contents of CROP PROCESSING - K

FEEDING Reel feeding AFX8010	K.25.B
FEEDING Header feeding AFX8010	K.25.D
FEEDING Feeder housing AFX8010	K.25.E
FEEDING Transition cone AFX8010	K.25.K
THRESHING Axial flow threshing AFX8010	K.40.C
SEPARATING Rotary separator AFX8010	K.42.C
STORING AND HANDLING Grain storing AFX8010	K.60.B
CLEANING Primary cleaning AFX8010	K.62.B
CLEANING Tailings return system AFX8010	K.62.C
CLEANING Self-levelling frame AFX8010	K.62.D
RESIDUE HANDLING Straw chopper AFX8010	K.64.C
RESIDUE HANDLING Chaff Spreader AFX8010	K.64.D
RESIDUE HANDLING Straw beater AFX8010	K.64.E
UNLOADING Grain unloading AFX8010	K.72.B
PROTECTION SYSTEMS Stone trapping AFX8010	K.90.E

Chapters

Each Chapter is identified by a letter and number combination e.g. Engine B.10.A The first letter is identical to the Section letter i.e. Chapter B.10 is inside Section B, Power Production.

CONTENTS

The Chapter Contents lists all the technical data (specifications), functional data (how it works), service data (remove, install adjust, etc..) and diagnostic data (fault codes and troubleshooting) that have been written in that Chapter for that function or system on the machine.

Contents

POWER PRODUCTION

ENGINE _ 10.A

TECHNICAL DATA

ENGINE - General specification (B.10.A - D.40.A.10) 3

AFX8010

FUNCTIONAL DATA

ENGINE - Dynamic description (B.10.A - C.30.A.10) 4

AFX8010

SERVICE

ENGINE - Remove (B.10.A - F.10.A.10) 5

AFX8010

DIAGNOSTIC

ENGINE - Troubleshooting (B.10.A - G.40.A.10) 6

AFX8010

INDEX

The Chapter Index lists in alphabetical order all the types of information (called Information Units) that have been written in that Chapter for that function or system on the machine.

Index

POWER PRODUCTION - B

ENGINE

ENGINE - Dynamic description (B.10.A - C.30.A.10) 4

AFX8010

ENGINE - General specification (B.10.A - D.40.A.10) 3

AFX8010

ENGINE - Remove (B.10.A - F.10.A.10) 5

AFX8010

ENGINE - Troubleshooting (B.10.A - G.40.A.10) 6

AFX8010

Information Units and Information Search

Each chapter is composed of information units. Each information unit has the ICE code shown in parentheses which indicates the function and the type of information written in that information unit. Each information unit has a page reference within that Chapter. The information units provide a quick and easy way to find just the right piece of technical information you are looking for.

example information unit	Stack valve - Sectional View (A.10.A.18 - C.10.A.30)				
Information Unit ICE code	A	10.A	18	C	10.A.30
ICE code classification	Distribution systems	Primary hydraulic power	Stack valve	Functional data	Sectional view

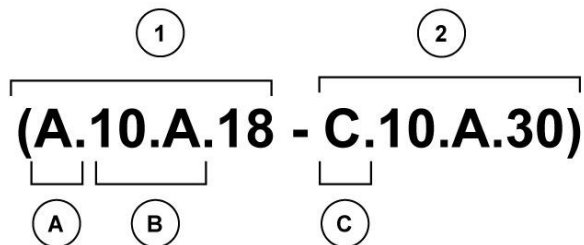

CRIL03J033E01 1

Navigate to the correct information unit you are searching for by identifying the function and information type from the ICE code.

- **(1)** Function and **(2)** Information type.
- **(A)** corresponds to the sections of the repair manual.
(B) corresponds to the chapters of the repair manual.
(C) corresponds to the type of information listed in the chapter contents, Technical data, Functional Data, Diagnostic or Service.
(A) and **(B)** are also shown in the page numbering on the page footer.
THE REST OF THE CODING IS NOT LISTED IN ALPHA-NUMERIC ORDER IN THIS MANUAL.
- You will find a table of contents at the beginning and end of each section and chapter.
You will find an alphabetical index at the end of each chapter.
- By referring to **(A)**, **(B)** and **(C)** of the coding, you can follow the contents or index (page numbers) and quickly find the information you are looking for.

Page Header and Footer

The page header will contain the following references:

- Section and Chapter description

The page footer will contain the following references:

- Publication number for that Manual, Section or Chapter.
- Version reference for that publication.
- Publication date
- Section, chapter and page reference e.g. A.10.A / 9



REPAIR MANUAL

DISTRIBUTION SYSTEMS

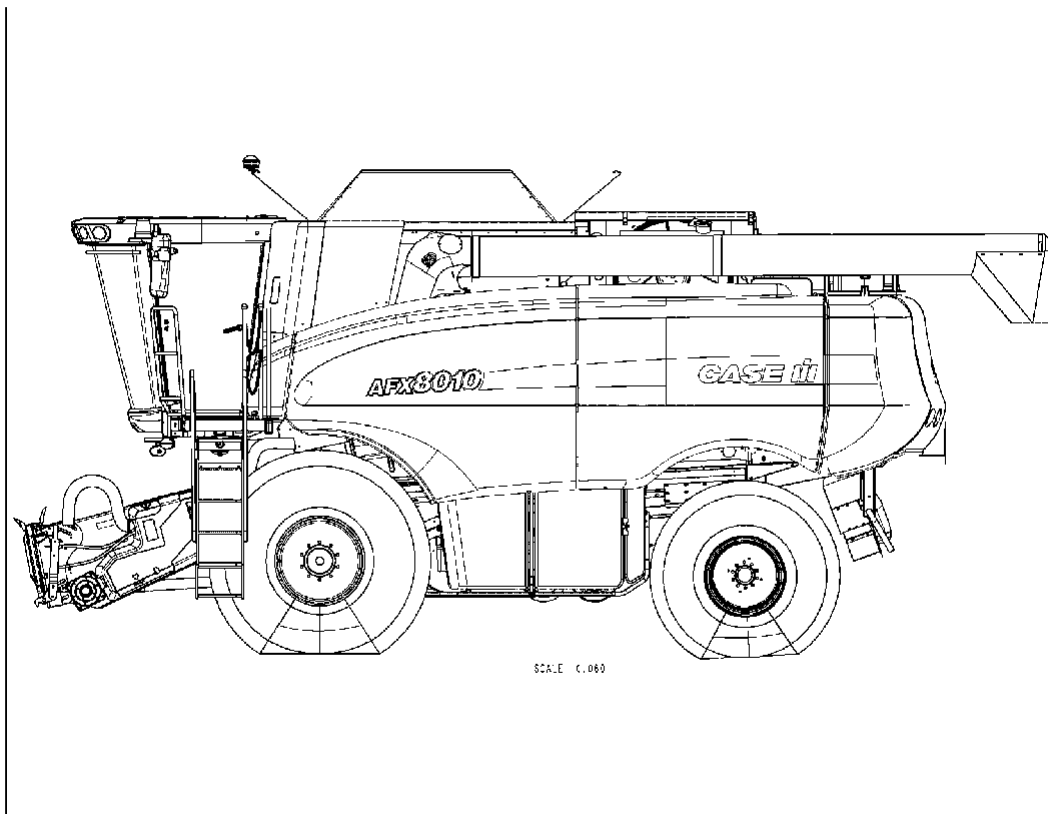

AFX8010

Contents

DISTRIBUTION SYSTEMS - A

PRIMARY HYDRAULIC POWER SYSTEM AFX8010	A.10.A
SECONDARY HYDRAULIC POWER SYSTEM AFX8010	A.12.A
ELECTRICAL POWER SYSTEM AFX8010	A.30.A
LIGHTING SYSTEM AFX8010	A.40.A
ELECTRONIC SYSTEM AFX8010	A.50.A



DISTRIBUTION SYSTEMS - A

PRIMARY HYDRAULIC POWER SYSTEM - 10.A

AFX8010

DISTRIBUTION SYSTEMS - A

PRIMARY HYDRAULIC POWER SYSTEM - 10.A

CONTENTS

FUNCTIONAL

Description	Page
Basic Principles Of The System	5
General Information	7
Specifications	8
Hydraulic System	9
Hydraulic Component Locations	10
Oil Supply	11
Filtration	12
Cooling	12
Gear Pumps	13
Hydraulic Schematic	14
PFC Pump Hydraulic System	18
PFC Pump Schematic	18
PFC Component Locations	19
Signal Circuits	29
Steering Priority Valve	30
Electrical Monitoring Circuits	36
Regulated Pressure	37
Park Brake / Regulated Pressure Valve	37
Component Location	38
Regulated Pressure Schematic	38
Regulated Pressure Valve Operation	39
Electrical Monitoring Circuits	40
Control Pressure	41
Control Pressure Pump	45
Filtration	46
Control / Lubrication Pressure Valve	47
Control Pressure Schematic	48
Electrical Monitoring Circuits	50

PTO Gearbox Cooling and Lubrication System	51
Lubrication System	52
PTO Gearbox Cooling.....	55
Electrical Monitoring Circuits.....	56
DIAGNOSTIC	
Hydraulic System Testing Procedures	57
Diagnostic Test Equipment.....	58
Hydraulic System Testing Procedures	60
# 1 Low Pressure Standby	61
# 2 High Pressure Standby	63
# 3 Steering Relief Setting.....	65
# 4 Bench Testing Components	67
# 5 Control Pressure Test	69
# 6 PTO Gear Box Lubrication Pressure Test.....	71
# 7 Regulated Pressure Test	73
#8 Spreader Pump Flow Test.....	75
# 9 Fan Pump Flow Test.....	77
# 10 PFC Pump Flow	79
# 11 Control Pressure Pump Flow Test.....	81
Signal valve	
Signal valve - Unidentified failure (A.10.A.12 - G.30.B.46)	83
Sensing system	
Sensing system Differential pressure switch - Short circuit to B+ (A.10.A.95.81- G.30.B.54)	87
Sensing system Temperature sensor - Short circuit to B+(A.10.A.95.90- G.30.B.54).....	90
Sensing system Temperature sensor - Short circuit to ground (A.10.A.95.90- G.30.B.53) ...	93
Sensing system Temperature sensor - Open circuit (A.10.A.95.90- G.30.B.50)	96
Sensing system Reservoir level sensor - Short circuit to B+ (A.10.A.95.93- G.30.B.54) ...	101

BASIC PRINCIPLES OF THE SYSTEM

Combines use a combination of Pressure Flow Compensated (PFC) and open-center hydraulics. In a **PFC** system, oil flow is minimal unless there is a hydraulic demand. In an **open-center** system, oil is constantly pumped through the system regardless of hydraulic demand.

Flow Across a Restriction

The hydraulic system of the combine uses the principle of flow across a restriction for some functions. It is important to understand this basic principle in order to understand how the system works, or more importantly, why the system may not be working.

1. When oil flows through an **unrestricted** passage, the pressure in this passage, if any, will remain constant as long as pump flow remains constant.
2. When oil in a passage **flows across a restriction**, the pressure after the restriction will be less than the pressure before that restriction. **Flow must exist for this to happen.** A restriction can occur by any component causing a resistance to flow.
3. When oil in a passage is **fully restricted** from flow (no-flow), the pressure in the passage will build until it reaches the relief valve setting. This relief pressure will be maintained as long as the flow is blocked and the pump is functioning normally. This is true regardless of what component is blocking flow. No flow will create constant pressure in the passage based on the relief valve setting.

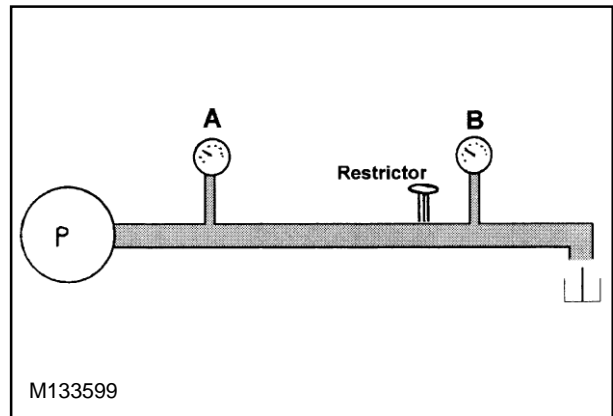

1

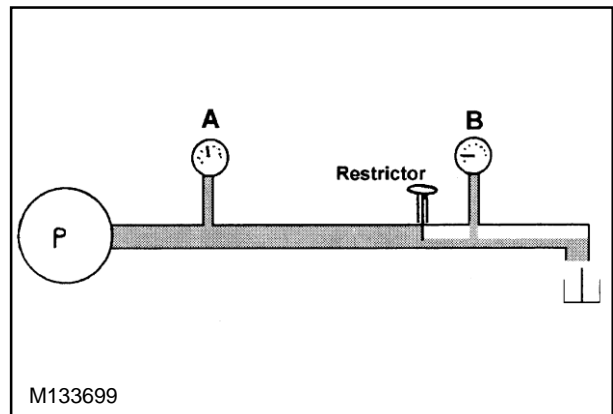

2

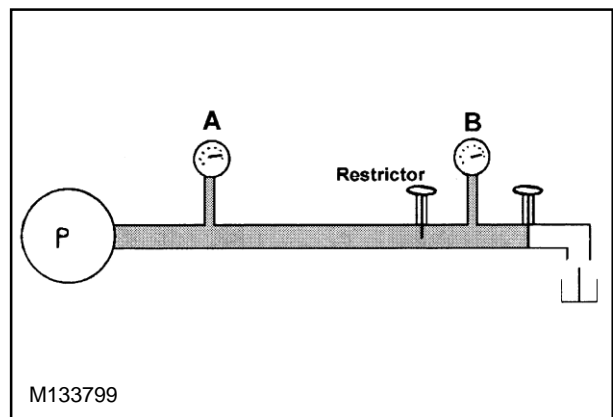

3

BASIC PRINCIPLES OF THE SYSTEM

Pilot Operated Hydraulic System

1. Pilot-operated hydraulic system has two basic parts or sections: A pilot (also called primary) section, and a main (also called secondary) section.
2. When a pilot-operated system is actuated, the pilot (primary) **always** moves first. Once the pilot has operated, the main (secondary) section **always** moves last. This is true whether the system is being activated or deactivated.
3. The movement of the pilot (primary) controls a very small amount of oil flow (pilot flow). The movement of the main (secondary) controls the majority of the oil flow (main flow) and is responsible for actuating a given system.

The header raise/header lower and reel drive valve are three examples of a pilot operated system used on the combine.

GENERAL INFORMATION

The AFX Axial-Flow combines use a very extensive hydraulic system to operate machine functions that are normally associated with belts and chains, along with the normal hydraulic functions. This section will cover the basics of the hydraulic supply system, each actual function will be included with that function's sections.

This section will cover the reservoirs, filtration, gear pumps, PFC pump and cooling. Since the machine incorporates two reservoirs, the hydraulic system is easily broken into two separate systems.

1. Hydraulics: Operator control functions
2. Control Pressure: Hydrostatic drives, associated valves and clutches

HYDRAULICS Hydraulic Reservoir	CONTROL PRESSURE PTO Gearbox Reservoir
Steering	Ground Drive
Header Raise / Lower	Rotor Drive
Reel Fore / Aft, Raise, and Drive	Feeder Drive
Lateral Tilt	Chopper Clutch
Unloading Auger Swing	Unloader Clutch
Fan Drive	Lubrication
Spreader Drive	
Rotary Air Screen	
Parking Brake / Tow Valve	
Regulated Pressure	

The two systems will incorporate several hydraulic pumps and motor to complete the required operations.

HYDRAULICS Hydraulic Reservoir		HYDROSTATICS PTO Gearbox Reservoir	
PFC Pump	Steering Header Raise / Lower Lateral Tilt Unloading Auger Swing Reel Fore / Aft and Raise Reel Drive Park Brake / Tow Valve Regulated Pressure	Control Circuit Pump	Beater/Chopper Clutch Unloader Clutch Ground Drive Rotor Drive Feeder Drive
Fan Pump	Fan Drive Motor	Lube Pump	Lubrication
Spreader Pump	Spreader Drive Motor and Rotary Air Screen Motor		

SPECIFICATIONS

Component	Specification
Electrical	
Parking Brake / Regulated pressure sensor	0.0 PSI = 0.5V signal wire C
Control pressure sensor	Normal PSI = 3V signal wire C
Hydraulic filter restriction switch	N/O, Closes at 2.75 bar (40 PSID)
Control pressure filter restriction switch	N/O, Closes at 2.75 bar (40 PSID)
Hydraulic return oil temperature sensor	2500ohms @ room temperature
Motor Temp. (Ground Drive) sensor	83 ohms @ 128°C (262°F)
Reservoir tank level switch	N/C, Closed with low oil 0.0 ohms
Hydraulic	
Spreader motor relief	210 bar (3000 PSI)
Rotary air screen motor relief	24 bar (350 PSI)
Fan motor relief	241 bar (3500 PSI)
Oil cooler by-pass (Hydraulic cooler)	7.6 bar (110 PSI)
Hydraulic filter by-pass	3.45 barD (50 PSID)
Regulated pressure	22- 25 bar (320- 360 PSI)
Control pressure filter by-pass	3.45 barD (50 PSID)
Control pressure relief	20- 22 bar (290- 320 PSI) Hot 23- 25 bar (340- 360 PSI) Cold
Lubrication pump / cooler relief	20 bar (290 PSI)
Lubrication system relief	3.5 bar (50 PSI)
PFC pump low pressure stand-by	26- 28 bar (375- 400 PSID)
PFC pump high pressure stand-by	207- 214 bar (3000- 3100 PSI)
Steering relief	183- 190 bar (2650- 2750 PSI)
Reel drive relief	138 bar (2000 PSI)
Header Tilt cushion relief	207 bar (3000 PSI)
Feeder lift cylinder thermal relief	276 bar (4000 PSI)
Spreader drive pump flow	63 l/m (16.5 GPM)
Fan drive pump flow	51 l/m (13.5 GPM)
PFC pump flow	152 l/m (42 GPM)
Control pressure pump flow	150 l/m (39.5 GPM)
Lubrication pump flow	92.7 l/m (23.5 GPM)

HYDRAULIC SYSTEM

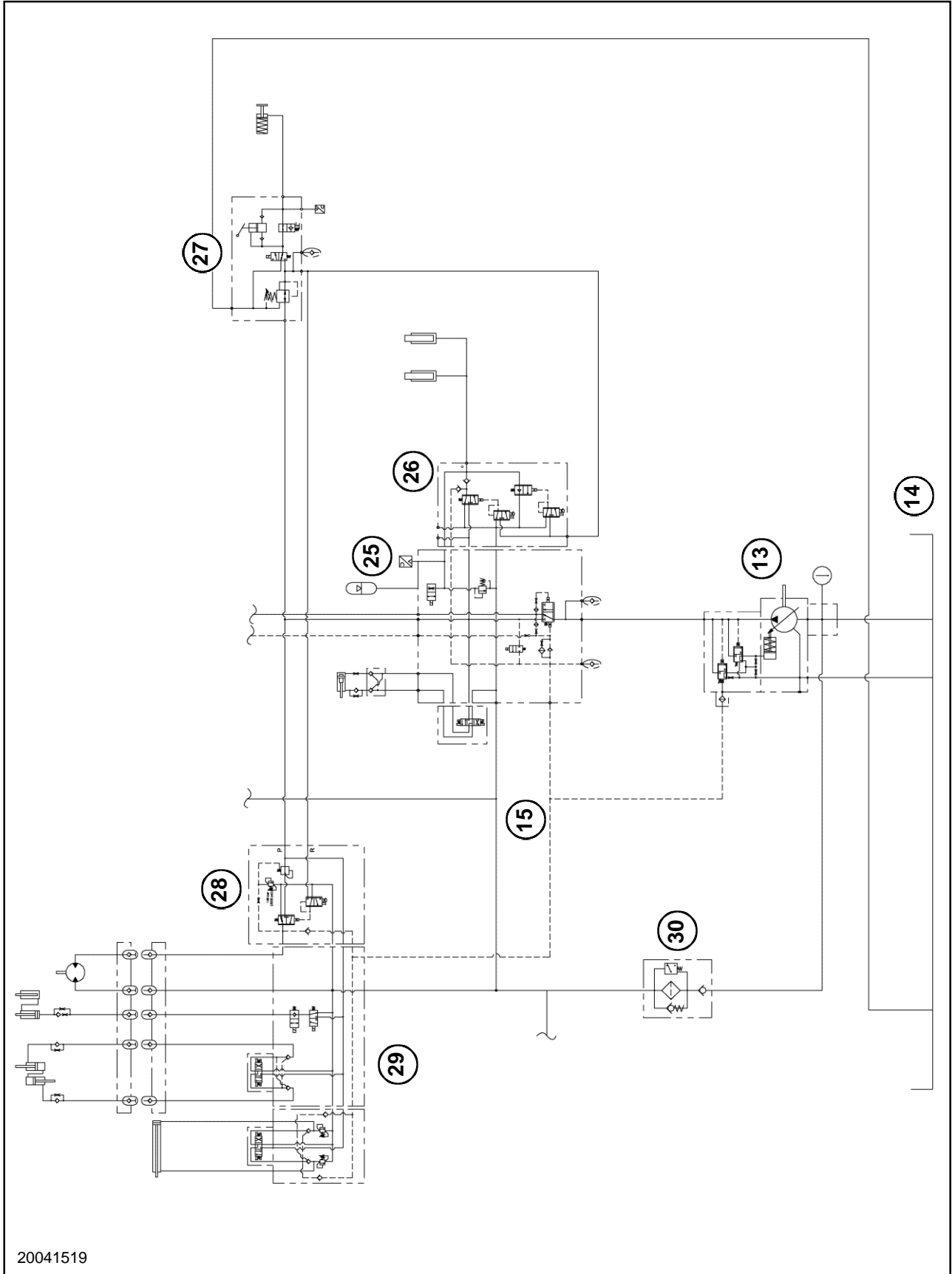

20041519

Hydraulic Component Locations

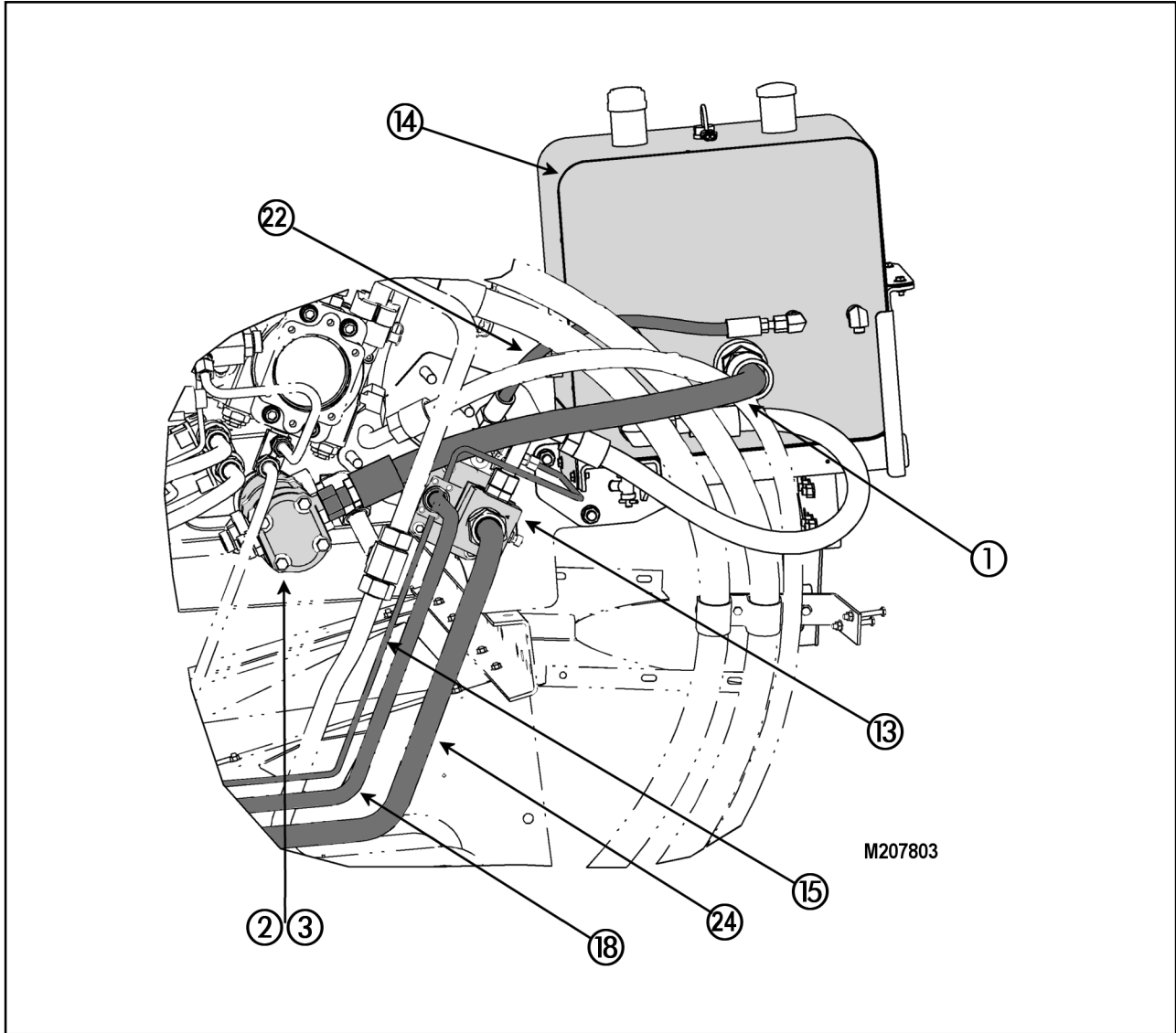

5

- | | |
|---|---|
| 1. Supply to Spreader and Fan Pumps | 24. PFC Pump Suctions |
| 2&3. Gear Pump Assembly, Spreader and Fan Drive | 25. Main Valve Assembly |
| 13. PFC Piston Pump | 26. Header Lift Valve |
| 14. Hydraulic Reservoir | 27. Park Brake / Regulated Pressure Valve |
| 15. Signal Line to Compensator | 28. Reel Drive Valve |
| 18. PFC Pump Discharge Line | 29. Feeder Valve Assembly |
| 22. PFC Pump Case Drain | 30. Hydraulic Return Filter |

Oil Supply

1. Oil Level Sight Glass
2. Oil Level Sensor
3. Reservoir Tank
4. Outlet Strainer
5. Tank Drain

The hydraulic system is supplied with Hy-Tran Ultra from a central reservoir tank that is mounted behind the PTO gearbox. The tank contains approximately 57L (15 gal) of oil and should be changed out every 1000 hours of operation.

A float type gauge that is mounted in the top of the tanks monitors the proper oil level. The float provides an Open/Closed signal to the Universal Display Plus monitor. The switch is N.C. when held in the operating position, open when oil is present.

The tank incorporates a discharge port strainer and tank breather. The strainer is rated at 100 micron of protection and supplies the gearpumps.

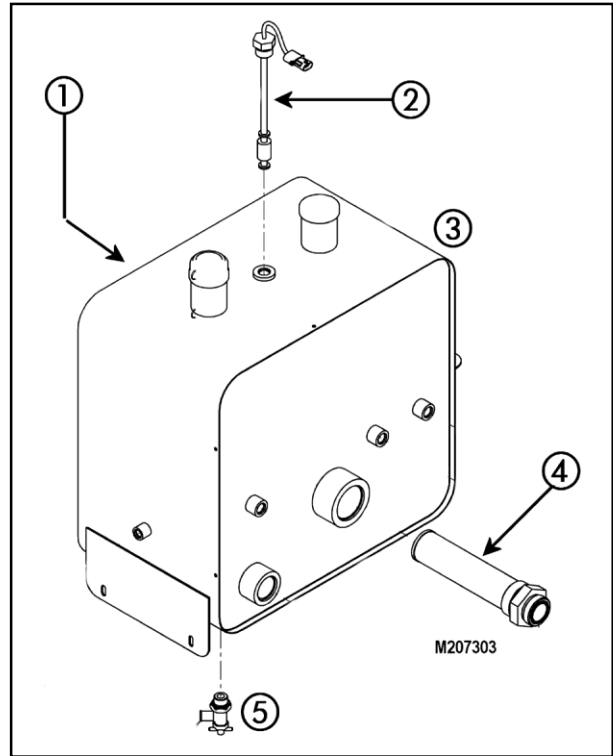

Filtration

- 2. Discharge Port
- 3. Not used on the hydraulic filter
- 4. Inlet Port
- 10. Filter By-Pass
- 11. Restrictions Indicator
- 12. Back Flow Check Valve

The hydraulic filter is on the return side of the hydraulic system, prevent trash from reaching the reservoir tank. It is imperative that only CLEAN Hy-Tran Ultra is placed in the tank. The filter base incorporates a filter restriction sensor (11) that monitors the condition of the filter element. If the restriction increases above 2.76 bar (40 PSID) differential pressure the sensor will CLOSE to create a signal to the Universal Display Plus monitor for operator warning. The filter base incorporates a filter by-pass valve that will open at 3.45 bar (50 PSID) differential pressure to prevent over pressuring the filter. The sensor is set to activate prior to the by-pass valve opening.

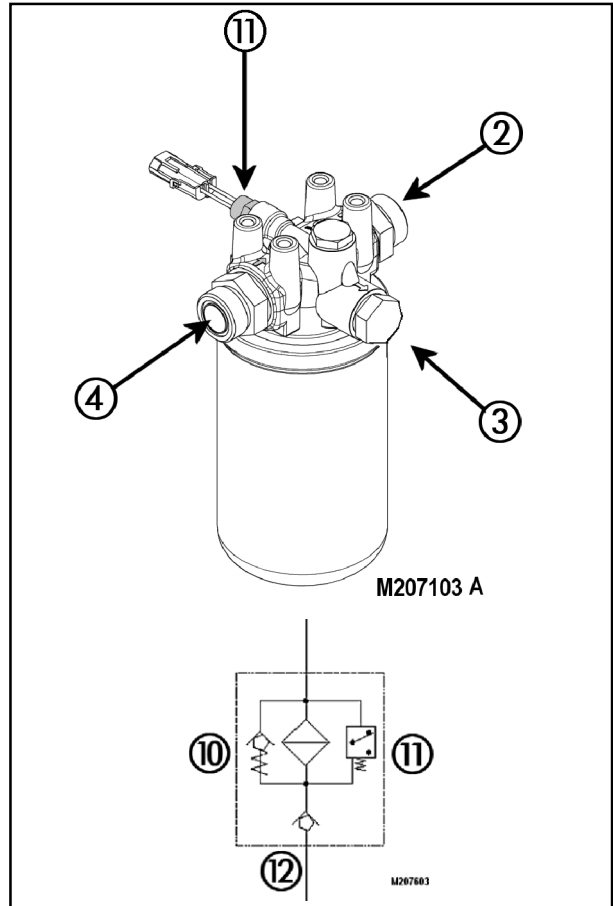

7

Cooling

- 1. Intercooler
- 2. Radiator
- 3. PTO Gearbox Oil Cooler
- 4. Hydraulic Oil Cooler
- 5. Air Conditioning Condenser
- 6. Fuel Cooler

The hydraulic cooler is mounted behind the rotary air screen and is the Lower third of the center cooler. There is a 7.6 bar (110 PSI) oil cooler by-pass valve mounted in the lower front corner to protect the cooler.

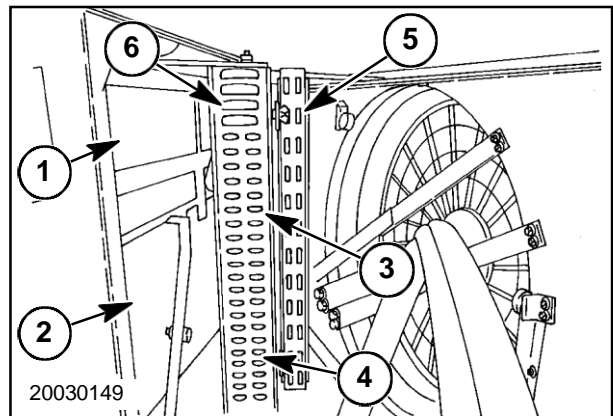

8

Gear Pumps

1. Fan Drive Output (rear pump)
2. Spreader and Rotary Air Screen Output (center pump)
3. Control Pressure Output (front pump)
4. Supply From PTO Gearbox, (for pump 3)
5. Supply From Hydraulic Reservoir, (for pumps 1 and 2)

The gear pump assembly is mounted in the PTO gearbox and incorporates three separate gear pumps.

- The **Control Pressure** pump, (pump 3, nearest to the drive shaft), is supplied oil from the **PTO gearbox** and all of its flow is returned to the PTO gearbox. See specification page.
- The **Spreader/Rotary Air Screen Drive** pump is supplied oil from the **hydraulic reservoir** and returns all of its flow back to the reservoir. See specification page.
- The **Fan Drive** pump is supplied oil from the **hydraulic reservoir** and returns all of its flow back to the reservoir. See specification page.

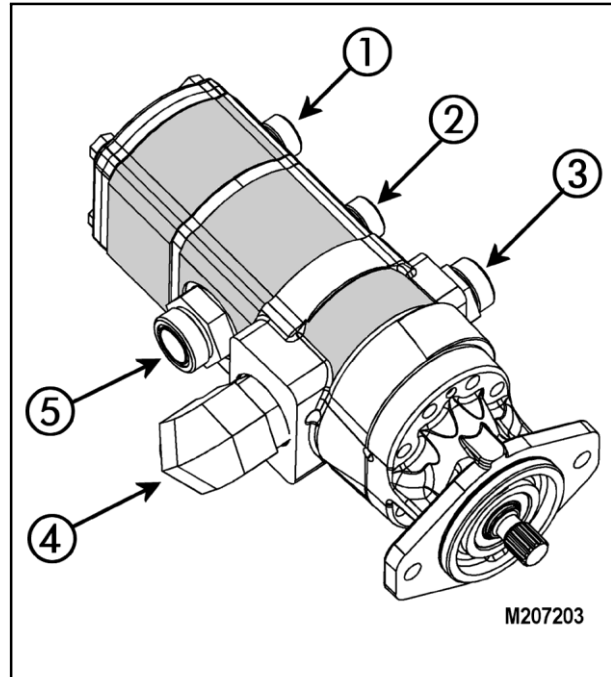

9

NOTE: If the seal was to leak between the front and center pumps oil could transfer between reservoirs.

Hydraulic Schematic

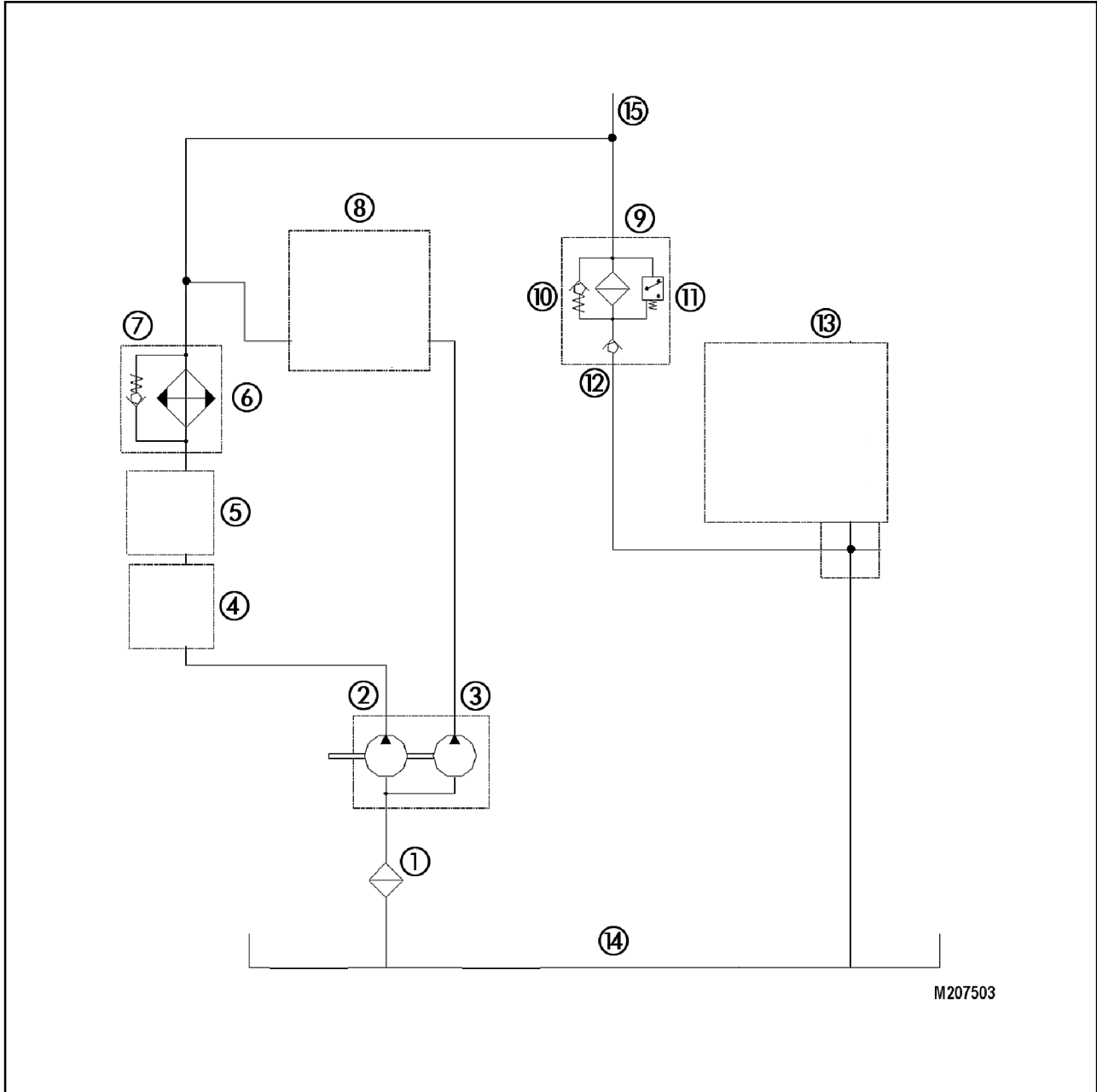

M207503

- | | |
|--|---|
| 1. Reservoir Strainer | 9. Return Filter Base |
| 2. Spreader/Rotary Air Screen Drive Pump | 10. Filter By-Pass Valve |
| 3. Fan Drive Pump | 11. Filter Restriction Indicator Switch |
| 4. Spreader Drive Valve | 12. Back Flow Check Valve |
| 5. Rotary Air Screen Valve | 13. PFC Piston Pump |
| 6. Oil Cooler | 14. Reservoir Tank |
| 7. Oil Cooler By-Pass Valve | 15. Return From All Hydraulic Functions |
| 8. Fan Drive Valve | |

Hydraulic Schematic

Spreader Pump

The spreader pump (2) will pull oil from the hydraulic reservoir (14) and direct it to the spreader valve (4). The spreader valve will direct the full flow of pump on to the rotary air screen valve (5) once the spreader operation is completed. The rotary air screen valve will direct the full flow of pump on to the oil cooler (6) once the air screen operation is completed. In cold weather the cooler may cause excessive restriction

so the by-pass valve (7) can direct the oil flow around the cooler the filter housing (9). The filter restriction is monitored by the filter sensor (11) and is protected by the by-pass valve (10). The filter directs the flow to the PFC pump inlet and the reservoir tank.

IMPORTANT: *The spreader pump being a gear pump is associated with an open center system. In an open center system the pump flow is constant and MUST be routed back to the reservoir at all times. It can not be deadheaded or serious failures can occur.*

Hydraulic Schematic

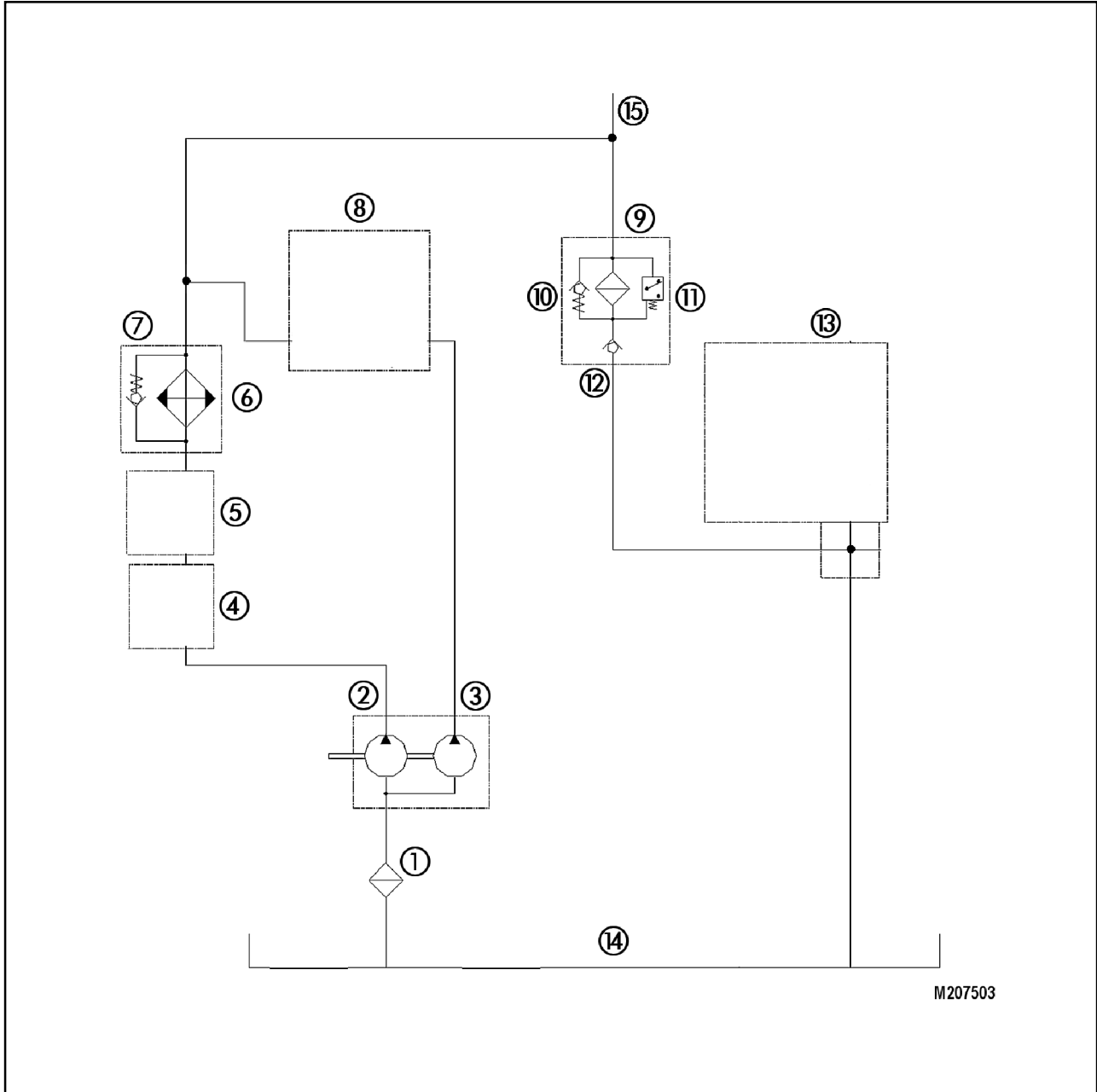

M207503

- 1. Reservoir Strainer
- 2. Spreader/Rotary Air Screen Drive Pump
- 3. Fan Drive Pump
- 4. Spreader Drive Valve
- 5. Rotary Air Screen Drive Valve
- 6. Oil Cooler
- 7. Oil Cooler By-Pass Valve
- 8. Fan Drive Valve

- 9. Return Filter Base
- 10. Filter By-Pass Valve
- 11. Filter Restriction Indicator Switch
- 12. Back Flow Check Valve
- 13. PFC Piston Pump
- 14. Reservoir Tank
- 15. Return From All Hydraulic Functions

Hydraulic Schematic

Fan Pump

The fan pump (3) will pull oil from the hydraulic reservoir (14) and direct it to the fan valve (8). The fan valve will direct the full flow of pump into the flow from the spreader pump headed to the filter base (9). The filter restriction is monitored by the filter sensor (11) and is protected by the by-pass valve (10). The filter directs the flow to the PFC pump inlet and the reservoir tank.

IMPORTANT: *The fan pump being a gear pump is associated with an open center system. In an open center system the pump flow is constant and MUST be routed back to the reservoir at all times. It can not be deadheaded or serious failures can occur.*

Pressure Flow Compensating (PFC) Pump Hydraulic System

PFC Pump Schematic

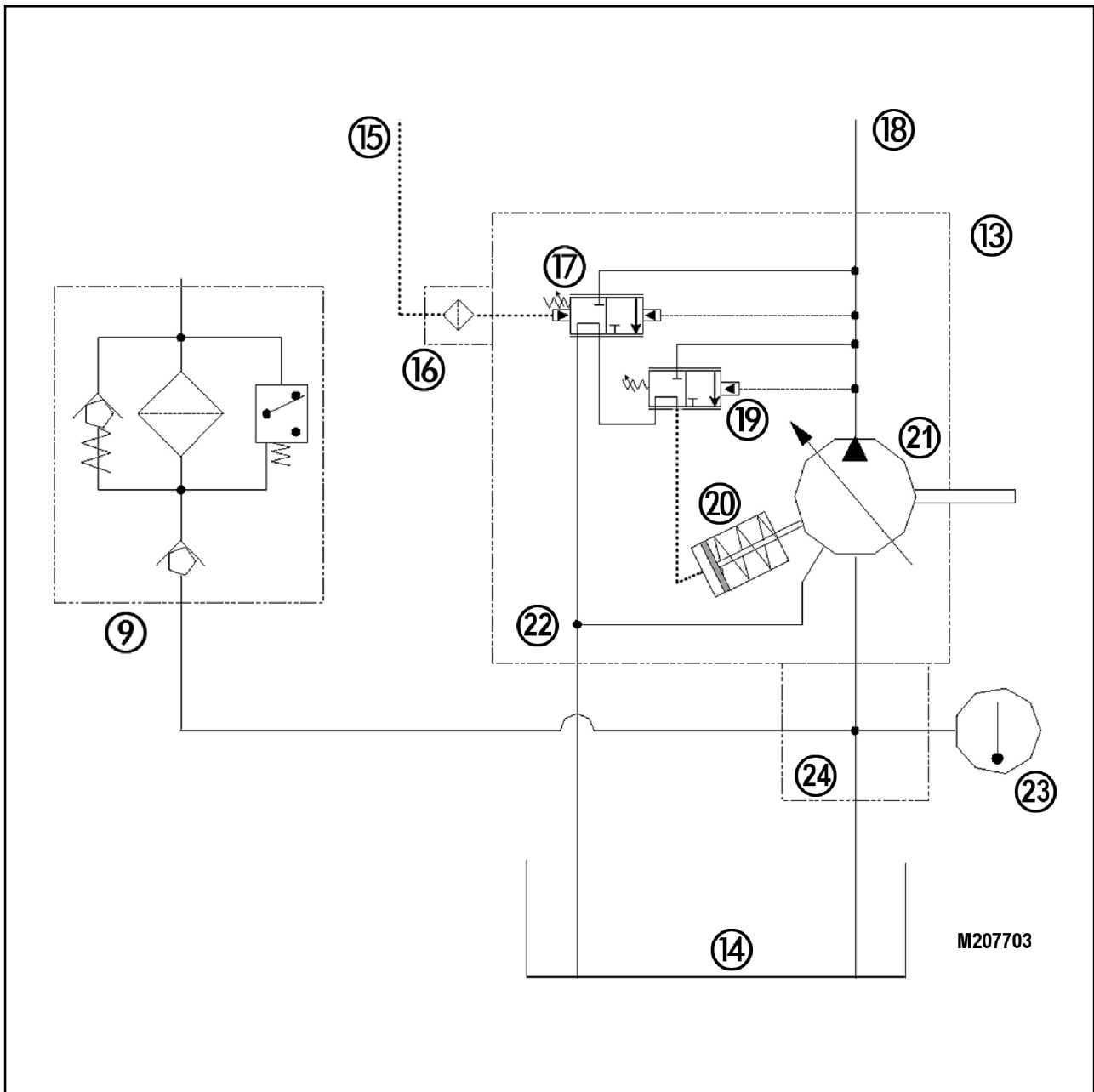

12

- | | |
|--------------------------------|-------------------------------|
| 9. Return Filter Base | 19. High Pressure Spool |
| 13. PFC Pump Assembly | 20. Servo Piston (swashplate) |
| 14. Hydraulic Reservoir | 21. Rotating Assembly |
| 15. Signal Line to Compensator | 22. Case Drain |
| 16. Signal Line Screen | 23. Temperature Sensor |
| 17. Flow Control Spool | 24. Supply Manifold |
| 18. Pump Discharge Port | |

>> BUY NOW

download online

Manual