

PERFORMANCE DATA

FINISHER (TIER 3)

BF 300 C



[DOWNLOAD SERVICE REPAIR MANUAL HERE](#)



Greatest durability



Shorter set-up times



Exemplary efficiency

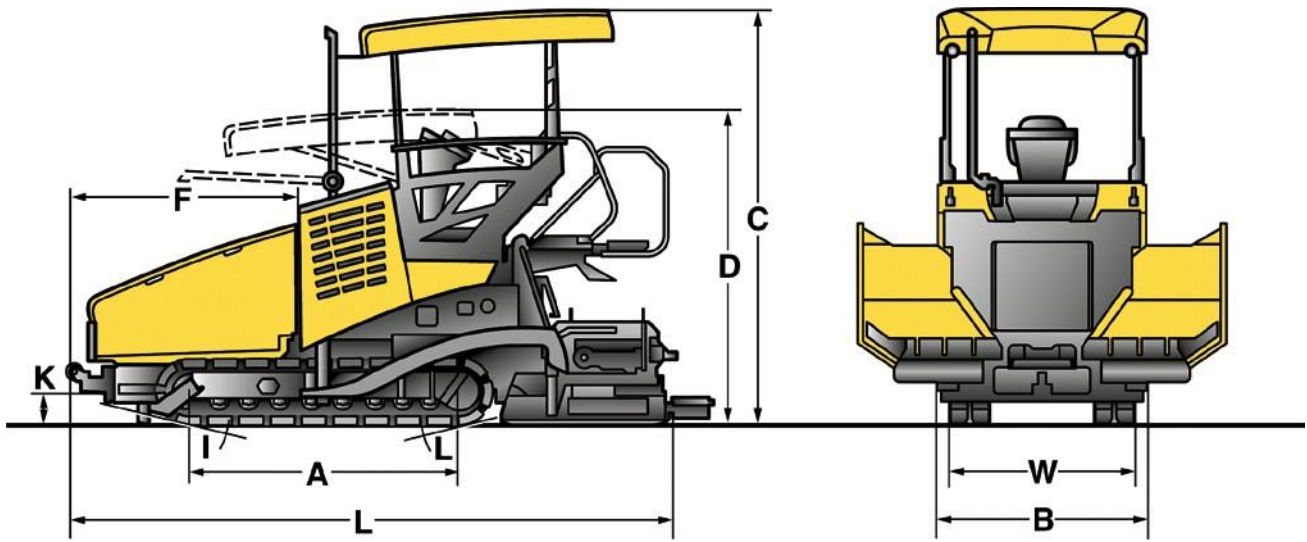

Dimensions in mm

| | A | B | H | H ₂ | K | L | W |
|-----------------|------|------|------|----------------|-----|------|------|
| BF 300 C | 2200 | 1740 | 3350 | 2600 | 170 | 4950 | 1700 |

Shipping dimensions in m³

| | |
|------------------------------|--------|
| BF 300 C, S 340-2 EV | 22,394 |
| BF 300 C, S 340-2 ETV | 22,394 |



Optional weather protection – for maximum convenience.

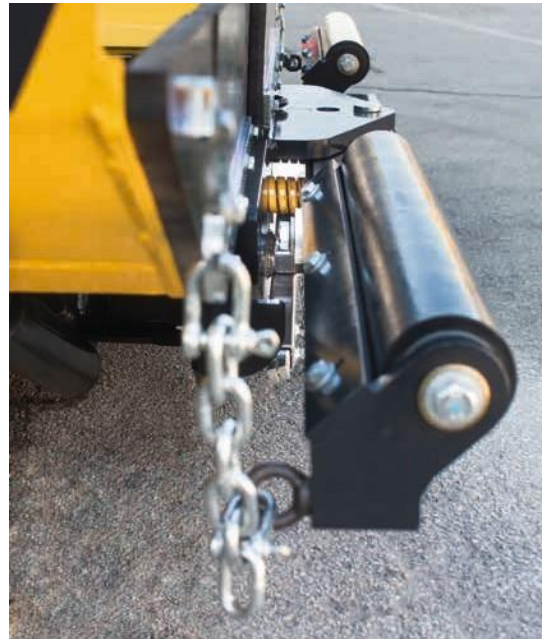

Impact-free docking – dampened bumper.



Heats up nearly 60 % quicker – unique MAGMALIFE heating system.

Technical Data**Weights**

Operating weight CECE kg

Dimensions

Transport length mm

Transport width mm

Transport height mm

Travel characteristics

Travel speed (1) km/h

Working speed (1) m/min

Drive

Engine manufacturer

Type

Emission stage

Cooling

Number of cylinders

Rated power ISO 3046..... kW

Rated speed min⁻¹**Crawler assembly**

Crawler track

-Axle base mm

-Width..... mm

HopperCapacity m³

Width (wings open)..... mm

Width (wings closed) mm

Length mm

Filling height (middle)..... mm

Scraper belt / auger

Number.....

Width mm

Speed m/min

Individual control.....

Reversing operation

Conveyor auger

->Number

->Auger diameter mm

->Rated speed 1/min

->Reversing operation.....

Screed

Screed type

Basic width retracted mm

Basic width extended..... mm

Max. working width mm

Min. width with reduction skids..... mm

Mat. thickness..... mm

Smoothing plate depth..... mm

Smoothing plate thickness..... mm

Heating

Crown %

Tamp frequency..... Hz

Vibration frequency..... Hz

Basic weight..... kg

Filling capacities

Fuel..... l

Hydraulic oil..... l

Operating/control elements

Number of drier's seats.....

Side View.....

LCS System

BOMAG**BF 300 C, S 340-2 EV**

8280

4950

1740

2600

0-4,9

0-26

Kubota

V3307 T

Stage III a / TIER 3

Water

4

55,4

2200

2200

260

4,8

3075

1740

1660

540

2

220

30

Standard

Standard

2

280

100

Standard

S 340-2 EV

1700

3400

5000

750

250

330

12

Electric

-3 ... +4,5

20-50

20-50

1500

100

80

1

Standard

Standard

BOMAG**BF 300 C, S 340-2 ETV**

8500

4950

1740

2600

0-4,9

0-26

Kubota

V3307 T

Stage III a / TIER 3

Water

4

55,4

2200

2200

260

4,8

3075

1740

1660

540

2

220

30

Standard

Standard

2

280

100

Standard

S 340-2 ETV

1700

3400

5000

750

250

330

12

Electric

-3 ... +4,5

0-30

20-50

1720

100

80

1

Standard

Standard

Standard equipment

- ECOMODE
- Lateral seat ad platform adjustment, Side View System (pat.)
- GRP-roof, hydr. tiltable, 4-fold roof lighting
- L.C.S. Screed relief system
- Individually controlled hopper wings
- Reversible and individually controlled scraper belts
- Reversible and individually controlled augers
- Continuous tamper and vibration adjustment
- Fully automatic screed heating
- Cast heating elements
- BOMAG central electrics, service and fault code display
- Hydr. pre-tensioning of crawler tracks with overload protection
- Remote control of material flow sensors from the lateral screed control panels
- Mechanical crown adjustment
- Electro-mechanical sensors for scraper belts
- Ultrasound sensors for augers
- Central lubrication for screed and auger

Optional equipment

- Screed extension 30 cm, 50 cm (3.4 m to 5.0 m)
- Cleaning kit
- Hydraulic auger lift
- Ultrasound sensors for scraper belts
- Hydraulic crown adjustment
- Optional paint finish
- Ultrasound or electro-mechanical levelling systems
- Cross-slope levelling system
- Electric side plate heating for screed S340E
- Automatic central lubrication system for screed and auger
- Spring-mounted pushing roller yoke

