

NEBRASKA OECD TRACTOR TEST 1884—SUMMARY 551

JOHN DEERE 8130 DIESEL

16 SPEED

Location of tests: Nebraska Tractor Test Laboratory, University of Nebraska, Lincoln, Nebraska 68583-0832

Dates of tests: September 19 - October 5, 2006

Manufacturer: John Deere Tractor Works, 3500 East Donald St., P.O. Box 270, Waterloo Ia, 50704-0270

FUEL, OIL and TIME: Fuel No. 2 Diesel Specific gravity converted to 60°/60°F (15°/15°C) 0.8409 Fuel weight 7.002 lbs/gal (0.839 kg/l) Oil SAE 15W-40 API service classification CI-4 Transmission and hydraulic lubricant John Deere Hy-Gard fluid Front axle lubricant John Deere Hy-Gard fluid Total time engine was operated: 29.0 hours

ENGINE: Make John Deere Diesel Type six cylinder vertical with turbocharger and air to air aftercooler Serial No.*RG6090L005575* Crankshaft lengthwise Rated engine speed 2100 Bore and stroke 4.661" x 5.354" (118.4 mm x 136.0 mm) Compression ratio 16.3 to 1 Displacement 548 cu in (8984 ml) Starting system 12 volt Lubrication pressure Air cleaner two paper elements and aspirator Oil filter one full flow cartridge Oil cooler engine coolant heat exchanger for crankcase oil, radiator for hydraulic and transmission oil Fuel filter one paper element and water separator Fuel cooler radiator for pump return fuel Muffler vertical Cooling medium temperature control 2 thermostats and variable speed fan

ENGINE OPERATING PARAMETERS: Fuel rate: 69.4 - 75.2 lb/h (31.5 - 34.1 kg/h) High idle: 2175 - 2225 rpm Turbo boost: nominal 19.6 - 23.9 psi (135 - 165 kPa) as measured 22.2 psi (153 kPa)

CHASSIS: Type front wheel assist Serial No.*RW8130P003963* Tread width rear 60.0" (1524 mm) to 132.6" (3368 mm) front 64.0" (1625 mm) to 88.0" (2235 mm) Wheelbase 120.1" (3050 mm) Hydraulic control system direct engine drive Transmission selective gear fixed ratio with full range operator controlled power shift Nominal travel speeds mph (km/h) first 1.12 (1.81) second 1.51 (2.43) third 2.01 (3.24) fourth 2.69 (4.33) fifth 3.02 (4.86) sixth 3.48 (5.60) seventh 4.05 (6.51) eighth 4.66 (7.50) ninth 5.39 (8.67) tenth 6.21 (9.99) eleventh 7.21 (11.61) twelfth 8.31 (13.38) thirteenth 9.80 (15.77) fourteenth 13.12 (21.12) fifteenth 17.47 (28.12) sixteenth 23.41 (37.67) reverse 1.06 (1.70), 2.83 (4.55), 3.57 (5.74), 6.55 (10.54)@1500 engine rpm Clutch wet multiple dishydraulically actuated by foot pedal Brakes wet multiple disc hydraulically operated by two foot pedals that can be locked together Steering hydrostatic Power take-off 1000 rpm at 2003 engine rpm Unladen tractor mass 21320 lb (9670 kg)

POWER TAKE-OFF PERFORMANCE

Power HP (kW)	Crank shaft speed rpm	Gal/hr (l/h)	lb/hp.hr (kg/kW.h)	Hp.hr/gal (kW.h/l)	Mean Atmospheric Conditions
MAXIMUM POWER AND FUEL CONSUMPTION					
Rated Engine Speed—(PTO speed—1047 rpm)					
182.22 (135.88)	2099	10.34 (39.15)	0.397 (0.242)	17.62 (3.47)	
Standard Power Take-off Speed(1000 rpm)					
197.60 (147.35)	2006	10.81 (40.91)	0.383 (0.233)	18.29 (3.60)	
Maximum Power (1 hour)					
208.27 (155.31)	1700	11.29 (42.73)	0.379 (0.231)	18.45 (3.63)	

VARYING POWER AND FUEL CONSUMPTION

182.22 (135.88)	2100	10.34 (39.15)	0.397 (0.242)	17.62 (3.47)	Air temperature
158.89 (118.48)	2154	9.55 (36.17)	0.421 (0.256)	16.63 (3.28)	76°F (24°C)
119.73 (89.28)	2166	8.01 (30.33)	0.469 (0.285)	14.94 (2.94)	Relative humidity
79.67 (59.41)	2175	6.38 (24.17)	0.561 (0.341)	12.48 (2.46)	25%
40.33 (30.07)	2185	5.07 (19.19)	0.880 (0.535)	7.95 (1.57)	Barometer
1.25 (0.93)	2192	3.67 (13.89)	20.582 (12.520)	0.34 (0.07)	29.13" Hg (98.65 kPa)

Maximum torque - 674 lb.-ft. (914 Nm) at 1600 rpm

Maximum torque rise - 48.0%

Torque rise at 1700 engine rpm - 41%

DRAWBAR PERFORMANCE UNBALLASTED - FRONT DRIVE ENGAGED FUEL CONSUMPTION CHARACTERISTICS

Power Hp (kW)	Drawbar pull lbs (kN)	Speed mph (km/h)	Crank-shaft speed rpm	Slip %	Fuel Consumption lb/hp.hr (kg/kW.h)	Hp.hr/gal (kW.h/l)	Temp. °F (°C) cooling med	Air dry bulb	Barom. inch Hg (kPa)
Maximum Power—8th Gear									
158.05 (117.86)	12660 (56.32)	4.68 (7.53)	2100	3.50	0.458 (0.279)	15.28 (3.01)	182 (83)	59 (15)	28.80 (97.53)
75% of Pull at Maximum Power—8th Gear									
123.29 (91.94)	9504 (42.28)	4.86 (7.83)	2156	2.48	0.507 (0.308)	13.82 (2.72)	185 (85)	63 (17)	28.80 (97.53)
50% of Pull at Maximum Power—8th Gear									
83.52 (62.28)	6341 (28.20)	4.94 (7.95)	2169	1.49	0.612 (0.372)	11.44 (2.25)	178 (81)	64 (18)	28.81 (97.56)
75% of Pull at Reduced Engine Speed—10th Gear									
123.59 (92.16)	9504 (42.27)	4.88 (7.85)	1623	2.48	0.454 (0.276)	15.42 (3.04)	182 (83)	64 (18)	28.81 (97.56)
50% of Pull at Reduced Engine Speed—10th Gear									
83.73 (62.44)	6340 (28.20)	4.95 (7.97)	1633	1.41	0.497 (0.302)	14.09 (2.78)	177 (80)	64 (18)	28.81 (97.56)

**Thank you very much
for reading.**

PLEASE CLICK HERE.

Then back to the site.

At the bottom of the

page,

free add to card.

Then get more free

DRAWBAR PERFORMANCE
UNBALLASTED - FRONT DRIVE ENGAGED - 2100 RPM
MAXIMUM POWER IN SELECTED GEARS

Power Hp (kW)	Drawbar pull lbs (kN)	Speed mph (km/h)	Crank- shaft speed rpm	Slip %	Fuel Consumption lb/hp.hr (kg/kW.h)	Hp.hr/gal (kW.h/l)	Temp. °F (°C) cool- ing med	Air dry bulb	Barom. inch Hg (kPa)
5th Gear									
140.13 (104.49)	18935 (84.23)	2.78 (4.47)	2140	13.62	0.507 (0.309)	13.80 (2.72)	179 (81)	47 (8)	29.00 (98.21)
6th Gear									
155.26 (115.78)	17110 (76.11)	3.40 (5.48)	2098	6.04	0.465 (0.283)	15.05 (2.96)	179 (82)	48 (9)	29.00 (98.21)
7th Gear									
156.68 (116.84)	14587 (64.89)	4.03 (6.49)	2099	4.27	0.464 (0.282)	15.08 (2.97)	182 (84)	60 (16)	28.80 (97.53)
8th Gear									
158.05 (117.86)	12660 (56.32)	4.68 (7.53)	2100	3.50	0.458 (0.279)	15.28 (3.01)	182 (83)	59 (15)	28.80 (97.53)
9th Gear									
157.50 (117.45)	10845 (48.24)	5.45 (8.76)	2098	2.69	0.459 (0.279)	15.27 (3.01)	182 (83)	60 (16)	28.80 (97.53)
10th Gear									
158.32 (118.06)	9410 (41.86)	6.31 (10.15)	2100	2.35	0.457 (0.278)	15.33 (3.02)	185 (85)	61 (16)	28.80 (97.53)
11th Gear									
154.43 (115.16)	7866 (34.99)	7.36 (11.85)	2099	1.88	0.467 (0.284)	15.00 (2.96)	186 (86)	61 (16)	28.80 (97.53)
12th Gear									
151.89 (113.26)	6687 (29.74)	8.52 (13.71)	2099	1.52	0.477 (0.290)	14.68 (2.89)	188 (86)	62 (17)	28.80 (97.53)

REPAIRS AND ADJUSTMENTS: No repairs or adjustments.

REMARKS: All test results were determined from observed data obtained in accordance with official OECD, SAE and Nebraska test procedures. For the maximum power tests the fuel temperature at the injection pump inlet was maintained at 113°F(45°C). The performance figures on this summary were taken from a test conducted under the OECD Code II test code procedure.

We, the undersigned, certify that this is a true and correct report of official Tractor Test No. **1884**, Nebraska Summary 551, December 8, 2006.

Roger M. Hoy
Director

M.F. Kocher
V.I. Adamchuk
J.A. Smith
Board of Tractor Test Engineers

TRACTOR SOUND LEVEL WITH CAB	Front Wheel Drive	
	Engaged dB(A)	Disengaged dB(A)
At no load in 8th gear	72.8	72.3
Transport speed-no load- 16th gear		73.9
Bystander in 16th gear		84.6

TIRES, BALLAST AND WEIGHT	With Ballast	Without Ballast
Rear Tires - No., size, ply & psi(kPa)	Four 480/80R46;***;12(85)	Two 480/80R46;***;19(130)
Ballast - Duals (total)	1770 lb (803 kg)	None
- Cast Iron (total)	1285 lb (583 kg)	None
Front Tires - No., size, ply & psi(kPa)	Two 420/90R30;**,19(130)	Two 420/90R30;**,19(130)
Ballast - Liquid (total)	None	None
- Cast Iron (total)	385 lb (175 kg)	None
Height of Drawbar	22.0 in (560 mm)	22.0 in (560 mm)
Static Weight with operator - Rear	15445 lb (7005 kg)	12595 lb (5713 kg)
- Front	9490 lb (4305 kg)	8900 lb (4037 kg)
- Total	24935 lb(11310 kg)	21495 lb (9750 kg)

DRAWBAR PERFORMANCE
UNBALLASTED-FRONT DRIVE ENGAGED - 1700 RPM
MAXIMUM POWER IN SELECTED GEARS

Power Hp (kW)	Drawbar pull lbs (kN)	Speed mph (km/h)	Crank- shaft speed rpm	Slip %	Fuel Consumption lb/hp.hr (kg/kW.h)	Temp. °F(°C) cool- ing dry bulb	Barom. inch Hg (kPa)		
5th Gear									
141.45 (105.48)	19116 (85.03)	2.77 (4.47)	2133	13.40	0.507 (0.308)	13.82 (2.72)	178 (81)	47 (8)	29.00 (98.21)
6th Gear									
158.01 (117.83)	18208 (80.99)	3.25 (5.24)	2054	8.13	0.466 (0.283)	15.04 (2.96)	179 (82)	48 (9)	29.00 (98.21)
7th Gear									
172.05 (128.30)	17454 (77.64)	3.70 (5.95)	1976	6.62	0.444 (0.270)	15.78 (3.11)	188 (87)	60 (16)	28.80 (97.53)
8th Gear									
178.87 (133.38)	16891 (75.13)	3.97 (6.39)	1833	6.27	0.435 (0.265)	16.09 (3.17)	194 (90)	59 (15)	28.80 (97.53)
9th Gear									
182.60 (136.16)	15935 (70.88)	4.30 (6.92)	1700	5.39	0.434 (0.264)	16.14 (3.18)	197 (92)	60 (16)	28.80 (97.53)
10th Gear									
184.55 (137.62)	13789 (61.34)	5.02 (8.08)	1700	4.09	0.431 (0.262)	16.25 (3.20)	201 (94)	60 (16)	28.80 (97.53)
11th Gear									
184.35 (137.47)	11758 (52.30)	5.88 (9.46)	1698	3.08	0.431 (0.262)	16.23 (3.20)	200 (94)	62 (17)	28.80 (97.53)
12th Gear									
183.96 (137.18)	10126 (45.04)	6.81 (10.96)	1696	2.52	0.432 (0.263)	16.19 (3.19)	201 (94)	62 (17)	28.80 (97.53)
13th Gear									
182.67 (136.22)	8493 (37.78)	8.07 (12.98)	1695	2.01	0.432 (0.263)	16.21 (3.19)	203 (95)	63 (17)	28.80 (97.53)

DRAWBAR PERFORMANCE
BALLASTED - FRONT DRIVE ENGAGED - 1700 RPM
MAXIMUM POWER IN SELECTED GEARS

Power Hp (kW)	Drawbar pull lbs (kN)	Speed mph (km/h)	Crank- shaft speed rpm	Slip %	Fuel Consumption lb/hp.hr (kg/kW.h)	Consumption Hp.hr/gal (kW.h/l)	Temp. °F(°C) cool- ing med	Air dry bulb	Barom. inch Hg (kPa)
3rd Gear									
118.63 (88.47)	22993 (102.28)	1.93 (3.11)	2154	9.60	0.544 (0.331)	12.86 (2.53)	182 (83)	64 (18)	28.70 (97.19)
4th Gear									
148.75 (110.92)	21941 (97.60)	2.54 (4.09)	2072	7.84	0.491 (0.299)	14.26 (2.81)	187 (86)	66 (19)	28.70 (97.19)
5th Gear									
158.21 (117.97)	21059 (93.68)	2.82 (4.53)	2028	6.95	0.468 (0.285)	14.95 (2.94)	191 (88)	70 (21)	28.70 (97.19)
6th Gear									
168.52 (125.66)	20147 (89.62)	3.14 (5.05)	1938	5.97	0.452 (0.275)	15.48 (3.05)	196 (91)	72 (22)	28.70 (97.19)
7th Gear									
178.71 (133.26)	19832 (88.22)	3.38 (5.44)	1786	5.38	0.435 (0.265)	16.08 (3.17)	201 (94)	75 (24)	28.70 (97.19)
8th Gear									
183.00 (136.46)	18300 (81.40)	3.75 (6.03)	1700	4.28	0.432 (0.263)	16.20 (3.19)	202 (94)	76 (24)	28.70 (97.19)
9th Gear									
184.27 (137.41)	15777 (70.18)	4.38 (7.05)	1699	3.15	0.428 (0.261)	16.34 (3.22)	203 (95)	77 (25)	28.70 (97.19)
10th Gear									
184.93 (137.91)	13635 (60.65)	5.09 (8.19)	1701	2.59	0.426 (0.259)	16.44 (3.24)	201 (94)	78 (26)	28.70 (97.19)
11th Gear									
183.25 (136.65)	11573 (51.48)	5.94 (9.56)	1700	2.04	0.437 (0.266)	16.03 (3.16)	202 (95)	79 (26)	28.70 (97.19)
12th Gear									
180.43 (134.55)	9851 (43.82)	6.87 (11.05)	1700	1.73	0.443 (0.269)	15.82 (3.12)	200 (94)	80 (27)	28.70 (97.19)
13th Gear									
179.85 (134.12)	8311 (36.97)	8.12 (13.06)	1699	1.41	0.441 (0.268)	15.88 (3.13)	200 (93)	81 (27)	28.70 (97.19)

THREE POINT HITCH PERFORMANCE (OECD Static Test)

CATEGORY:	III	III
Quick Attach: Yes		
Lift cylinders:	2 x 90 mm	2x100 mm
Maximum force exerted through whole range:	12588 lbs (56.0 kN)	15683 lbs (69.8 kN)
	<u>63 cc pump</u>	<u>85 cc pump</u>
i) Sustained pressure at compensator cutoff:	2990 psi (206 bar)	2990 psi (206 bar)
	two outlet sets combined three outlet sets combined	
ii) Pump delivery rate at minimum pressure and rated engine speed:	45.6 GPM(172.6 l/min)	61.6 GPM(233.0 l/min)
iii) Pump delivery rate at maximum hydraulic power:	45.6 GPM(172.6 l/min)	61.5 GPM(232.8 l/min)
Delivery pressure:	2474 psi (171 bar)	2443 psi (168 bar)
Power:	65.8 HP (49.1 kW)	87.7 HP (65.4 kW)
	single outlet set	
ii) Pump delivery rate at minimum pressure and rated engine speed:	40.7 GPM(154.1 l/min)	38.9 GPM(147.3 l/min)
iii) Pump delivery rate at maximum hydraulic power:	39.5 GPM(149.5 l/min)	36.9 GPM(139.7 l/min)
Delivery pressure:	2098 psi (145 bar)	2088 psi (144 bar)
Power:	48.3 HP (36.1 kW)	45.0 HP (33.5 kW)

HITCH DIMENSIONS AS TESTED—NO LOAD

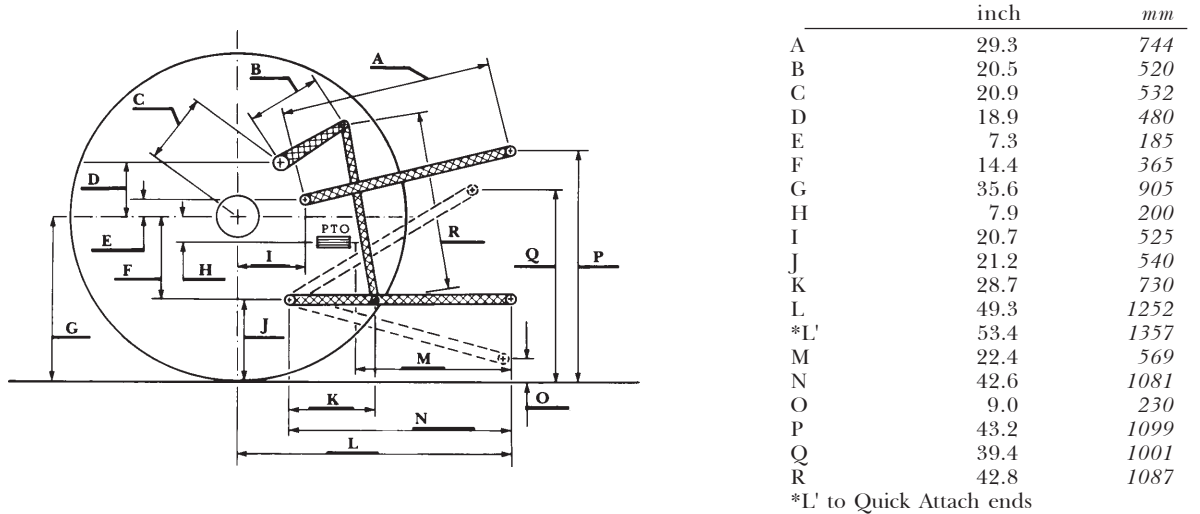

JOHN DEERE 8130 DIESEL

**Thank you very much
for reading.**

PLEASE CLICK HERE.

Then back to the site.

At the bottom of the

page,

free add to card.

Then get more free